

Monitor® AW

INSTRUCTION MANUAL AT-THE-WELL SCREW-IN CONTROL KIT FOR RECIPROCATING PUMPS

GENERAL

These instructions and parts list apply to the following Ordering Numbers:

(2-8) 8AWAPA

(2-8) 8AWAA

INSTALLATION

Follow the instructions for installing the Monitor Pitless Unit up to the point where the spool is attached to the drop pipe. Then proceed with the following: (Numbers in "()" apply to Figure 3).

1. Remove 3/8" pipe plug from spool.
2. Dope brass threads on bottom of flexible fluid separator assembly (6) and then screw assembly into spool.
3. Lower spool into pitless case while carefully uncoiling capillary tube. CAUTION: Avoid twisting or kinking tube.
4. **Remove jam nut, cap and rubber gasket that holds fluid in tube, (3) from upper brass fitting and then slide fitting through 5/8" hole in pitless unit cap. Replace jam nut and tighten. NOTE: Loss of fluid may cause switch to react inconsistently.**

5. Dope threads of upper brass fitting and then screw on pressure switch (2). CAUTION: Overtightening of pressure switch may crack hex portion of switch.
6. Connect electrical wiring. (Turn over pump by hand to check for correct adjustment). Turn on pump and operate for several minutes; then check for fluid leaks.
7. Check pressure switch setting.

TROUBLESHOOTING

CAUTION: Never remove pressure switch without first releasing all water system pressure. Not releasing all water system pressure will cause a loss of control fluid.

Loss of Control Fluid may be caused by:

- A. A leak between switch and upper brass fitting. **Remedy:** Leaks can be eliminated by use of plastic pipe dope on threads.
- B. Loose pressure switch diaphragm. **Remedy:** tighten screws that hold diaphragm.
- C. Cracked hex portion of pressure switch. **Remedy:** replace switch.

Cycling of Pressure Switch may be caused by:

- A. Too small a discharge line. **Remedy:** replace line; install buried tank or use smaller cylinder.
- B. Waterlogged pressure tank. **Remedy:** replace air volume control and/or drain or

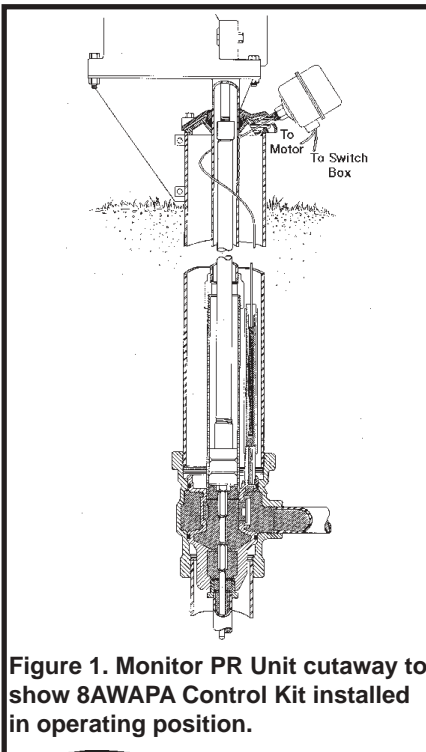

Figure 1. Monitor PR Unit cutaway to show 8AWAPA Control Kit installed in operating position.

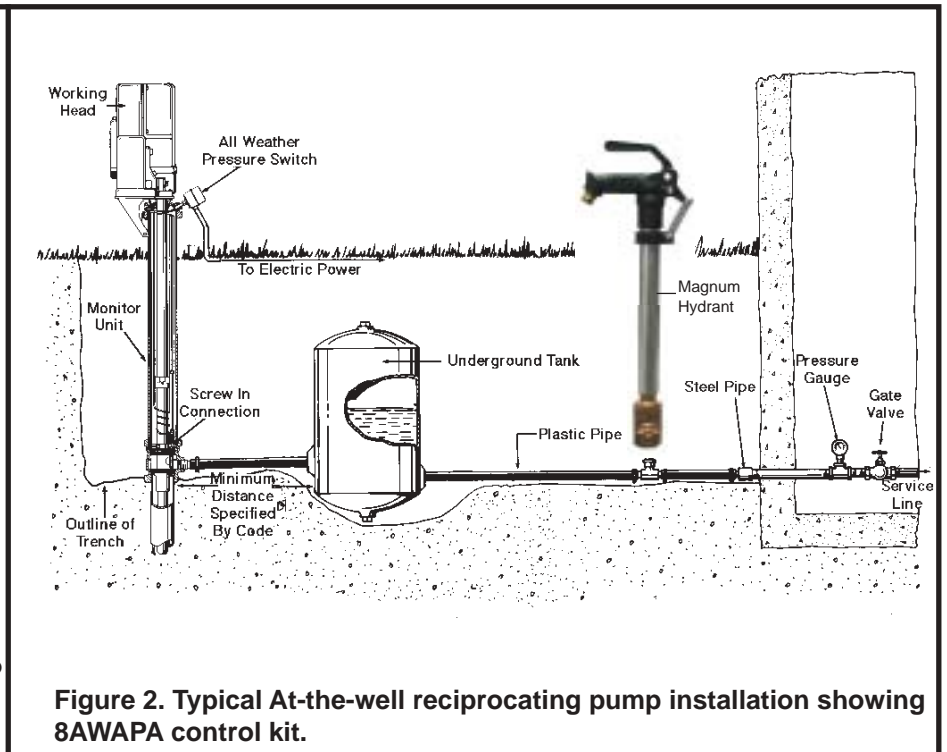

Figure 2. Typical At-the-well reciprocating pump installation showing 8AWAPA control kit.



pressure charge tank.

C. Inadequate differential setting on pressure switch.

Remedy: Increase setting until cycling stops.

Refilling Control with Fluid

1. Disconnect wires, remove switch, and then reconnect wires to pump.
2. Start pump and run until fluid is visible at top of the upper brass fitting (It will not be necessary to exceed 40 or 45 psi.).
3. Screw a 1/4" pipe coupling onto the brass fitting and then screw a piece of 1/4" pipe approximately 20" long into coupling and fill with Monitor pressure control fluid. Note: 3/8" I.D. plastic or rubber tubing may be used instead of the pipe.
4. Release system pressure and wait several minutes after the system pressure registers "0" psi before removing the tube or fittings.
5. Place pipe dope on the brass fitting and replace pressure switch.

IF EXTENSION FROM MALE BRASS FITTING IS REQUIRED, THIS ALSO MUST BE FILLED WITH FLUID.

NOTE: If tank is installed beyond 15' of control, use at your own risk.

NOTE: Pressure relief valve is recommended on all installations - 120 PSI maximum.

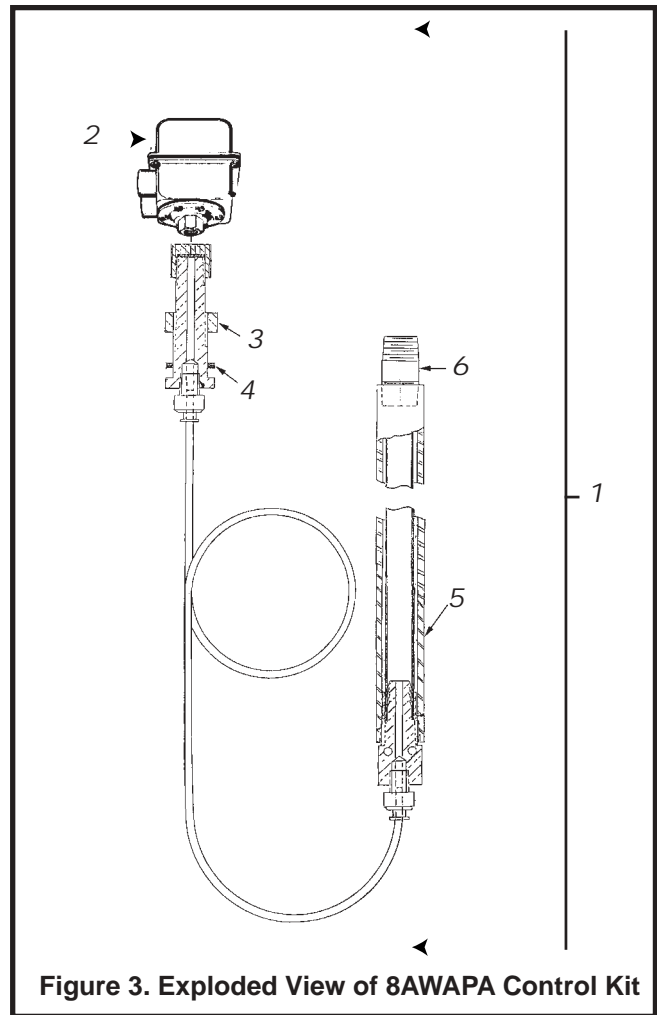

Figure 3. Exploded View of 8AWAPA Control Kit

Model No.			8AWAPA
Item	Qty	Description	Ord. No.
1	1	Control kit with pressure switch	8AWAPA
1	1	Same as 8AWAPA less pressure switch	8AWAA
2	1	All-weather pressure switch, 1/4" female tapping set 30-50 psi, 80 lbs. maximum, 2 horsepower	0AWP
3	1	Brass jam nut-5/8"	PS9
4	1	Gasket-7/8"x41/64"x1/16"	PS2
5	1	Tube housing, only -galvanized	PS15A
6	1	Galv. Nipple 3/8" x 1-1/2"	PS181
		Can of control fluid for 8AWAPA controls (Not illustrated).	8AWF