



- ◆PRINT THIS PAGE
- ◆VIEW REPAIR PARTS
- ◆BACK TO
- ◆HOME

## CONNECTIONS TO THE WELL

Monitor® PS Units are produced for two types of connections to the well; **KWIKONECT** and **THREADED**.

**KWIKONECT PITLESS UNITS**, for the first time, provide installers with a convenient, economical sanitary and permanent method of attachment to a well casing which can be completed in minutes. Until now, many methods of attachment have been used, some economical, some sanitary, but none were satisfactory from every aspect. The Monitor KwiKonec pitless unit uses a "Built-in" compression seal fitting to attach onto the top of the well casing. This type of seal has been used for permanent, watertight joints in piping for over 50 years. The convenient, economical KwiKonec pitless unit is the result of careful attention to design details and extensive testing.

- **FAST** . . . loosen bolts, slip unit onto well casing and tighten bolts. No disassembling required.
- **CONVENIENT** . . . No special tools needed to install. Through bolts tighten with a single wrench from the top where you can see them. There is no possibility of a broken bolt in a tapped hole.

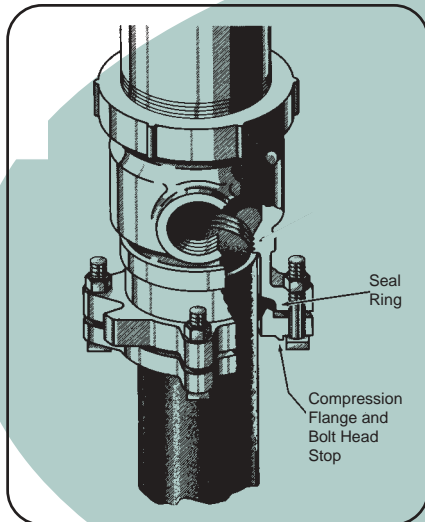

Monitor® PS Kwikonect Well Connection

The **KWIKONECT** units are connected by slipping the unit onto the top of the well casing and tightening the bolts.

The **THREADED** units require the top of the well casing to have a male thread of the proper size. This can be done by threading the well casing, or by using one of the methods shown below.

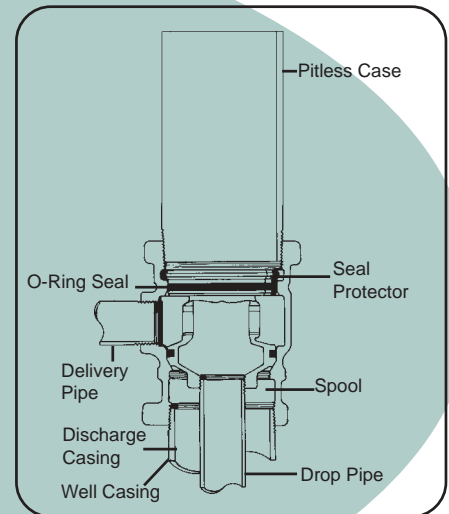

Monitor® PS Threaded Well Connection



**Welding Nipple**



**Pitless Connector**

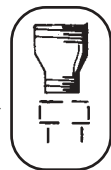

**Swagged Nipple**

**The Welding Nipple**—is male threaded on one end and chamfered on the other. For welding to the top of the casing.

**The Pitless Connector** – is female threaded on top and is slipped onto top of well casing and held in place by a neoprene seal ring which clamps against the casing.

**The Swagged Nipple** – Is male threaded both ends and screws into coupling on top of casing to increase casing size.



133 Enterprise Street  
Evansville, WI 53536