



- ◆PRINT THIS PAGE
- ◆VIEW REPAIR PARTS
- ◆BACK TO
- ◆HOME

SCREENED AIR VENT



SCREENED AIR VENT – The Screened Air Vent is a protected well vent for use on watertight cap installations. It consists of 24 mesh perforated brass screens assembled into a high quality iron casting. This engineered design protects the screen from any potential damage.

SCREENED AIR VENT

<u>Order No.</u>	<u>Tap Size</u>	<u>Wt.</u>
70PS	1"	2
71PS	1-1/4"	2.5
72PS	1-1/2"	3.5
73PS	2"	7
74PS	2-1/2"	11



133 Enterprise Street
Evansville, WI 53536

Figure 1 - 3WJ Cap for Jet Pump Installations

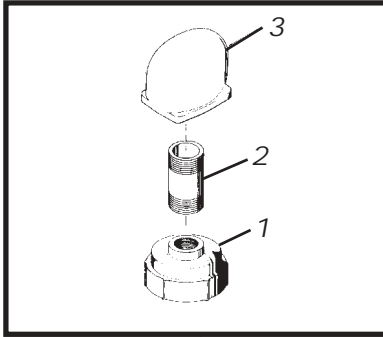
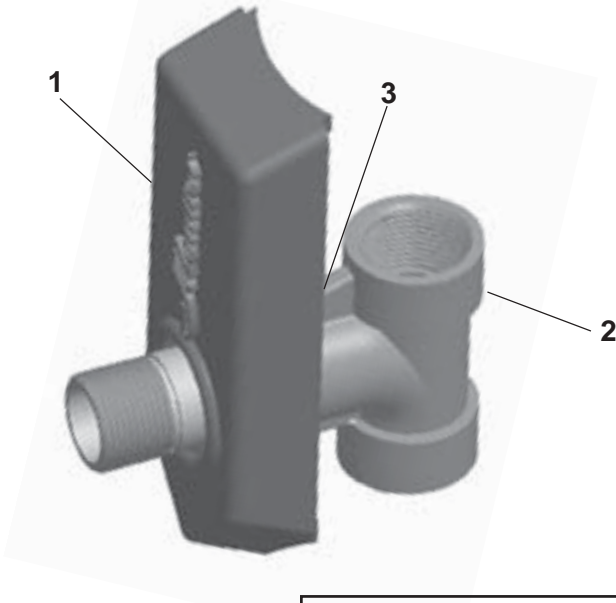

Figure 1 - 3WJ Cap for Jet Pump Installations			
Model No.			3WJ
Item	Qty	Description	Ord. No.
1	1	Watertight cap w/1" Tapping	NA31P
2	1	1 x 3 Galv. Nipple	PN13
3	1	Cap Vent & Screen	PS247

OM27 (1-1-95)

WELD ON PITLESS ADAPTERS

6123BEZ Weld On Pitless Adapter Installation Instructions



- Level Casting on Pipe
- Mark outside edges of casting
- Mark 1/4" inside right and left side only
- Cut left and right sides intersecting with top and bottom lines
- Check hole size with brass fitting before welding to be sure it is big enough

Model No.			6123BEZ
Item	Qty	Description	Ord. No.
1	1	Weldment	C6W
2	1	Adapter	BH61M
3	1	O-ring	PL3